

扳杠式卡箍型快开盲板（卧式）安装、使用、维护手册

Articulated type QOC (horizontal type) installation, use, maintenance manual

提示：在使用快开盲板之前请认真阅读本手册

Kind reminder: Please read this manual carefully before using the Quick opening closure.

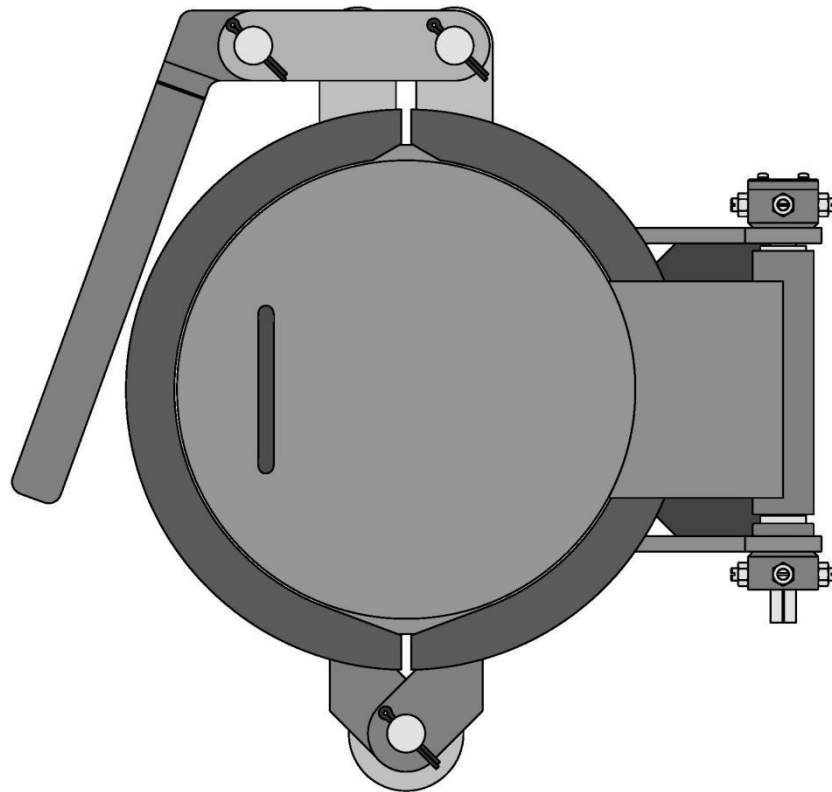

黑龙江省联尔顿石化设备有限公司

HEILONGJIANG LIANERDUN PETROCHEMICAL EQUIPMENT CO., LTD

地址：黑龙江省牡丹江市西安区牡丹街 764 号

Add: No. 764 Mudan Street, Xi'an District, Mudanjiang City, Heilongjiang Province

电话：0453-6427222 传真：0453-6426577

Tel: 0453-6427222 Fax: 0453-6426577

<http://www.ledpetro.com> E-Mail: sales1@ledpetro.com

目 录

catalog

1.快开盲板介绍 Introduction of QOC

- 1.1 产品特点 Product feature
- 1.2 基本结构 Basic structure
- 1.3 应用范围 Application range

2.安装 Install

- 2.1 初始安装 Initial installation
- 2.2 盲板盖的拆卸 Removal of end closure
- 2.3 焊接及焊后热处理 Welding and post-weld heat treatment
- 2.4 涂敷 Coating
- 2.5 盲板盖的重装 Reassembly of end closure

3.开关门操作 opening and closing operation

- 3.1 开门操作 opening operation
- 3.2 关门操作 closing operation

4.维护保养 Maintenance

- 4.1 存放 storage
- 4.2 检查 inspection
- 4.3 润滑 lubrication

5. 检查和润滑记录附表

Schedule of inspection and lubrication records

1. 快开盲板介绍 Introduction of QOC

1.1 产品特点 Product features

扳杠式卡箍型快开盲板咬合面积大，安全可靠，操作简单，开闭方便，适用于口径不大于 800mm 的设备上安装使用。带有安全联锁机构，充分确保安全可靠。

The Articulated type quick opening closure has a large occlusal area, high safety and reliability, simple operation, easy to open/close, and is more suitable for installation and use on diameter not more than 32" equipment. With safety interlock mechanism to fully ensure safety and reliability.

该产品主要由盲板盖、筒体、两瓣卡箍、安全联锁机构、转臂机构及开闭机构组成。向上或向下扳动开闭把手，两瓣卡箍即可涨开或收缩，从而达到快速开启和关闭的目的。

The product is mainly composed of end closure, barrel flange, double yoke clamp, safety interlock mechanism, swivel arm mechanism and opening and closing mechanism. Turning the Open/Close Handle up or down, the double yoke clamp can be opened or contracted, so as to achieve the purpose of quick opening and closing.

1.2 基本结构 Basic structure

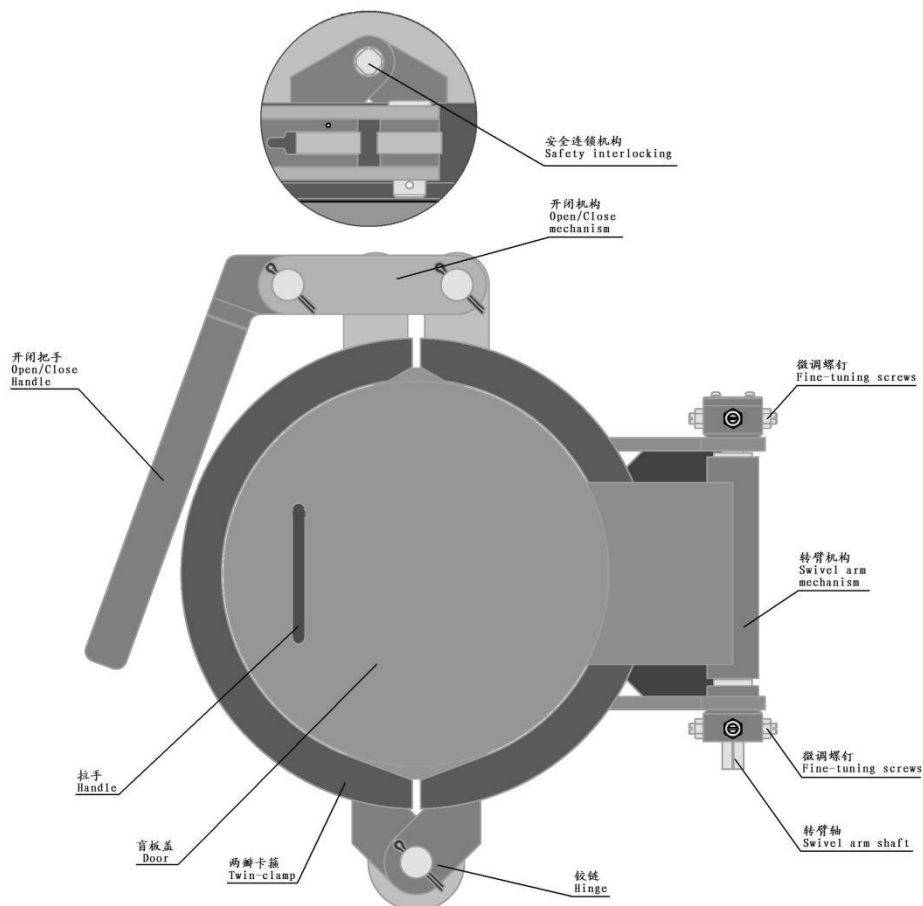

1.3 应用范围 Application range

该型式快开盲板广泛应用于天然气管线、化工、医药、冶金等各个领域中的如收发球筒、槽罐、增压釜、过滤分离器、换热器等需要不定期开闭的容器设备上。

This type of quick opening closure is widely used in natural gas pipeline, chemical industry, medicine, metallurgy and other fields, such as receiving and sending ball cylinder, tank, pressurized kettle, filtration separator, heat exchanger and other containers and equipments that need to be opened and closed from time to time.

2. 安装 Installation

2.1 初始安装 Initial installation

快开盲板初始安装，需符合以下要求：

Quick opening closure initial installation, need to meet the following requirements:

1)... 快开盲板内径应与设备内径一致，焊缝对口间隙应均匀一致，其最大与最小对口间隙之差 ≤ 1.0 毫米，对口错边量应符合 GB150.4-2011 标准中表 1 或者 ASME VIII div1 中表 UW-33 的规定；

1) The inner diameter of the quick opening closure should be consistent with the inner diameter of the equipment, the weld counter gap should be uniform, the difference between the maximum and minimum counter gap ≤ 1.0 mm, the amount of misalignment of the counter should be consistent with the provisions of GB150.4-2011 standards in Table 1 or Table UW-33 in ASME VIII div1 standard.

2)... 快开盲板与设备筒体组对之前，应先确定焊接型式：a.如采用双面焊，需拆下盲板盖（具体操作按本手册 2.2 盲板盖的拆卸）；b.如果采用单面焊，只需拿下密封圈即可，无需拆卸盲板盖；

2) Before the quick opening closure and the equipment barrel flange are grouped, the welding type should be determined: a. If double-sided welding is used, the end closure needs to be removed (specific operation according to the manual 2.2 Removal of end closure); b. If single-sided welding is used, just take down the sealing ring, no need to dismantle the end closure;

3) 快开盲板与设备筒体焊接之前，请仔细阅读本手册 2.3 焊接及焊后热处理。

3) Before welding the quick opening closure with the equipment barrel flange, please read carefully 2.3 Welding and post-welding heat treatment of this manual.

2.2 盲板盖的拆卸 Removal of the end closure

在快开盲板组装及维护需要拆卸盲板盖时，请按以下步骤进行：

When the assembly and maintenance of the quick opening closure requires disassembly of the end closure, follow the steps below:

1)... 将快开盲板合适放置，按本手册 3.1 开门操作，将盲板盖打开；

1) Place the quick opening closure in a suitable position and open the end closure according to 3.1 of this manual;

2)... 按图 1 所示，拆下转臂轴上盖，松开微调螺钉，（上下各 4 件，共 8 件），将转臂轴拆下。拆卸过程中应避免转臂轴螺纹部分磕碰损坏；

2)As shown in Figure 1, Remove the top cover of the swivel arm shaft, loosen the adjust screws, (4 pieces for each top and bottom, 8 pieces in total), and remove the swivel arm shaft. Avoid damage to the threaded portion of the swivel arm shaft by bumping it during disassembly;

3)... 卸下盲板盖并妥善放置。

3) Remove the end closure and place it properly.

2.3 焊接及焊后热处理 **Welding and post-weld heat treatment**

由于焊接过程中的焊接应力及焊接操作不当等原因，都可能导致焊接变形的产生，为防止和减小焊接变形，快开盲板与设备筒体组对及焊接时，应遵守以下规定：

Due to welding stress during the welding process and improper welding operation, etc., may lead to welding deformation, in order to prevent and minimize welding deformation, quick opening closure and equipment barrel flange pairing and welding, should comply with the following provisions:

1)... 对口间隙应均匀一致，最大与最小对口间隙之差 ≤ 1.0 毫米，对口错边量应符合 GB 150.4-2011 标准中表 1 或者 ASME VIII div1 中表 UW-33 的规定。

1) Counter gap should be uniform, the difference between the maximum and minimum counter gap ≤ 1.0 mm, the amount of counter misalignment should be in accordance with the GB150.4-2011 standard in Table 1 or Table UW-33 in ASME VIII div1 standard.

2)... 施焊前，需进行坡口预热或按焊接工艺规定执行；

2) Before applying welding, bevel preheating is required or according to the provisions of the welding process;

3)... 施焊时，应采用小直径焊条、小电流、对称焊、多层焊的焊接方法来控制焊接变形，否则可能导致盲板盖无法开启和关闭，甚至使快开盲板报废；

3) Welding, should use a small diameter electrode, small current, symmetrical welding, multi-layer welding method to control the welding deformation, otherwise it may lead to the end closure can not be opened and closed, and even make the quick opening closure scrapped!

焊后热处理建议：

Post-weld heat treatment recommendations:

1)... 对快开盲板与设备筒体之间的环焊缝进行热处理时，应尽量采用局部热处理；

1) When heat treatment is applied to the annular weld between the quick opening closure and the equipment barrel flange, local heat treatment should be applied as far as possible;

2)... 如果设备制造总图的技术要求中规定设备必须进行整体热处理时，必须用岩棉、硅酸铝或其它保温材料将密封面保护起来，防止过度氧化而影响密封；

2) If the technical requirements of the general drawing of equipment manufacturing stipulate that the equipment must be subjected to overall heat treatment, the sealing surface must be protected by rock wool, aluminum silicate or other insulating materials to prevent excessive oxidation from affecting the sealing;

3)... 热处理工艺严格按 GB150.4 第 8.2 条或 ASME VIII div1 UW-10 标准进行，或按热处理厂家成熟的热处理工艺进行；

3) The heat treatment process is carried out strictly in accordance with clause 8.2 of GB150.4 or ASME standards, or in accordance with the heat treatment process matured by the heat treatment manufacturer;

4)... 请注意： a.如果热处理前头盖已经拆下来，请在热处理之后进行头盖安装； b.如果热处理前头盖未拆卸，请务必将所有密封圈拿下来； c.热处理之后应使用细砂布将密封面轻微擦拭干净，并均匀涂抹润滑脂、甘油或防锈油。

4) Please note: a. If the end closure has been removed before heat treatment, please install the end closure after heat treatment; b. If the end closure has not been removed before heat treatment, please make sure to take down all the seals; c. The sealing surfaces should be lightly wiped clean with a fine emery cloth and evenly coated with grease, glycerin or antirust oil after the heat treatment.

2.4 涂敷 coating

快开盲板喷漆之前，必须将安全联锁机构卸下，将所有密封面、内外螺纹、紧固件、焊接坡口、不锈钢零部件、铜质件、电镀处理件等不需要喷漆的部分仔细包覆，以避免影响装配精度、使用性能、外形美观以及防止喷砂和油漆进入。

Before painting the quick opening closure, the safety interlocking mechanism must be removed, and all sealing surfaces, internal and external threads, fasteners, welded bevels, stainless steel parts, copper parts, plating treatment parts, and other parts that do not need to be painted must be carefully wrapped, in order to avoid affecting the assembly accuracy, performance, appearance, as well as preventing the ingress of sandblasted sand and paint.

2.5 盲板盖的重装 reset of the end closure

重新安装头盖时，请按以下要求进行：

When reinstalling the end closure, proceed as follows:

1)... 首先对所有密封面进行保护;

1) First protect all sealing surfaces;

2)... 拆下密封圈，将盲板盖与筒体对放好，使外径平齐，对齐后，再将盲板盖中心略微上移（由于装配过程中产生的累积公差及盲板盖的自重作用，装配之后，在开启盲板时，盲板盖会产生向下垂直位移。将盲板盖中心略微上移的目的就是为修正此位移）；

2) Remove the sealing ring, place the end closure and the barrel flange so that the outside diameter is flush, and then move the center of the end closure slightly upward after alignment (due to the cumulative tolerance generated during the assembly process and the self-weight of the end closure, the end closure will be displaced vertically downward when the end closure is opened after assembly. The purpose of moving the center of the end closure slightly upward is to correct this displacement);

3)... 装上转臂轴，拧紧转臂轴上下端的 8 个微调螺钉（紧固微调螺钉时必须避免转臂轴出现任何方向的位移）；

3) Install the swivel arm shaft and tighten the 8 adjust bolts at the upper and lower ends of the swivel arm shaft (any displacement of the swivel arm shaft in any direction must be avoided when tightening the adjust bolt);

4)... 安装转臂上盖；

4) Install the swivel arm shaft top cover;

5)... 进行开门试验，用专用扳手调整转臂轴下端，调整至盲板盖居中。

5) Carry out the door opening test, adjust the lower end of the swivel arm shaft with the special wrench and adjust it until the end closure is centered.

3. 开关门操作 **opening and closing operation**

3.1 开门操作 **Door opening operation**

注意：严格按以下要求和步骤进行！

Notice: Strictly follow the following requirements and steps.

1)... 开门前必须保证设备内压力为零，并严格遵守安全操作规程；

1) Before opening the door, the pressure inside the equipment must be ensured to be zero, and safe operating procedures must be strictly followed.

2)... 拧出安全联锁机构上的安全螺栓，此时，若设备内有残压，应立即停止拧出安全螺栓动作，重新检查设备压力，确认设备内部已完全卸压后（设备上压力表指针回零），方可拧出安全螺栓并卸下安全联锁机构；

2)unscrew the safety bolts on the Locking mechanism. If there is residual pressure in the equipment, should stop removing the safety bolt immediately and recheck the equipment pressure again. Ensure that the inside pressure relief is complete (the pressure gauge pointer on the equipment returns to zero) before unscrew the safety bolt and locking mechanism.

3)... 向上扳动开闭把手，使两瓣卡箍缓慢涨开至最大，达到盲板盖可开启状态，握住拉手打开盲板盖。

3) Trigger the opening and closing handles , so that the double yoke clamps slowly rise to the maximum, to reach the end closure can be opened state, hold the handle to open the end closure.

3.2 关门操作 closing operation

1)... 关门之前应仔细检查密封面、密封槽以及密封圈。密封面应擦拭干净，不允许有一切影响密封的杂物存在。检查密封圈是否有损坏，橡胶是否老化，如有缺陷，必须更换；

1)Before closing the door, should carefully check the sealing surface, sealing groove and sealing ring. The sealing surface should be wiped clean, and no debris affecting the sealing is allowed. Check whether the seal ring is damaged, whether the rubber is aging, if there are defects, it must be replaced;

2)... 在密封槽和密封面上均匀涂抹润滑油脂，然后将密封圈装入密封槽内（先装入 12、6 点钟方向，再装入 3、9 点钟方向）；

2)Evenly apply lubricating grease to the sealing groove and sealing surface, and then put the sealing ring into the sealing groove (first into the 12, 6 o'clock direction, then into the 3, 9 o'clock direction)

3)... 握住拉手，将盲板盖合上，向下扳动开闭把手，使两瓣卡箍收缩，直至密封面完全贴合；

3) Hold the handle, close the end closure, use the special wrench and rotate the switching screw in the direction indicated by the label, so that the double yoke clamp contracts until the sealing surface is completely fitted;

4)... 装入安全联锁机构并缓慢拧紧安全螺栓。

the safety interlock mechanism and slowly tighten the safety bolts.

4. 维护保养 Maintenance

4.1 存放 storage

如快开盲板需要储存，需将密封圈卸下，并将密封面、密封槽彻底清理干净，在表面均匀涂抹防锈油，然后将密封圈重新装入，用塑料布或其它包覆材料将快开盲板整体包裹好，放入包装箱储存于室内。

If the quick opening closure needs to be stored, the sealing ring should be removed and the sealing surface and sealing groove should be thoroughly cleaned, anti-rust oil should be evenly applied to the surface, then the sealing ring should be re-installed, and the quick opening closure should be wrapped up with a plastic sheet or other wrapping materials as a whole, and then put into a packing box for storing indoors.

4.2 检查 inspection

1)... 定期或不定期检查密封圈情况，观察密封圈是否有损坏或橡胶老化，如有缺陷必须更换；

1) Regularly or irregularly check the condition of seals, observe whether the seals are damaged or rubber aging, if defective must be replaced;

2)... 定期或不定期检查安全联锁机构是否完好，安全螺栓是否有断裂，密封圈是否有损坏或老化，如有缺陷必须更换；

2) Regularly or irregularly check whether the safety interlocking mechanism is intact, whether the safety bolt is broken, whether the sealing ring is damaged or aging, if defective must be replaced;

3)... 定期或不定期检查快开盲板是否开关灵活、可靠。长期使用后盲板盖因自重可能出现垂直位移，可按本手册 2.5 盲板盖的重装相关方法进行调整。

3) Regularly or irregularly check whether the quick opening closure is flexible and reliable. Vertical displacement of the end closure may occur after long-term use due to self-weight, which can be adjusted according to the method related to the reassembly of the end closure in 2.5 of this manual.

4.3 润滑 lubrication

定期在快开盲板各注油孔加注润滑油以保证快开盲板开关灵活。

Regularly add lubricant to the oiling holes of the quick opening closure to ensure that it is flexible.

5. 检查和润滑记录附表

Schedule of inspection and lubrication records

检查记录 Inspection record

检查日期 Inspection date	密封圈 seal ring	安全联 锁机构 safety interlocking mechanism	开、关 open / close	检查人 insp ector	备注 remarks

(实施后请打✓) Tick after implementation

润滑记录 Lubrication records

润滑日期 Lubrication date	检查人 insp ector	备注 remarks

(实施后请打✓)

Tick after implementation

黑龙江省联尔顿石化设备有限公司

HEILONGJIANG LIANERDUN PETROCHEMICAL EQUIPMENT CO., LTD

地址：黑龙江省牡丹江市西安区牡丹街 764 号

Add:No.764 Mudan Street,Xi' an District,Mudanjiang City,Heilongjiang Province

电话：0453-6427222 传真：0453-6426577

Tel:0453-6427222 Fax:0453-6426577

<http://www.ledpetro.com> E-Mail:sales1@ledpetro.com